

PHARMACOPOEIAL DISCUSSION GROUP

SIGN-OFF DOCUMENT

G-06 TABLET FRIABILITY

REVISION 1

Harmonised attributes

	EP	JP	USP
Purpose	+	+	+
Apparatus	+	+	+
Procedure	+	+	+

Legend

+ will adopt and implement; – will not stipulate

Non-harmonized attributes

None.

Local requirements

EP	JP	USP
None	None	None

European Pharmacopoeia

Signature

*P. Dörr*

Name

*Petra Dörr*

Date

*7 June 2022*

Japanese Pharmacopoeia

Signature

*Yukihiro Goda*  
*for Y. Yoshida*

Name

*Yukihiro Goda*

Date

*24 May / 2022*

United States Pharmacopoeia

Signature

*K. J. Moore*

Name

*KEVIN MOORE*

Date

*19-MAY-2022*

1  
2  
3  
4  
5  
6  
7  
8  
9  
10  
11  
12  
13  
14  
15  
16  
17  
18  
19

### TABLET FRIABILITY

#### PURPOSE

This chapter provides guidelines for the friability determination of compressed, uncoated tablets. The test procedure presented in this chapter is generally applicable to most compressed tablets. The measurement of tablet friability supplements other physical strength tests, such as tablet breaking force.

#### APPARATUS

Use a drum, with an internal diameter between 283.0 and 291.0 mm and a depth between 36.0 and 40.0 mm, of transparent synthetic polymer with polished internal surfaces, and subject to minimum static build-up (see figure for a typical apparatus). One side of the drum is removable. The tablets are tumbled at each turn of the drum by a curved projection with an inside radius between 75.5 and 85.5 mm that extends from the middle of the drum to the outer wall. The outer diameter of the central ring is between 24.5 and 25.5 mm. The drum is attached to the horizontal axis of a device that rotates from 24 to 26 rpm. Thus, at each turn the tablets roll or slide and fall onto the drum wall or onto each other.

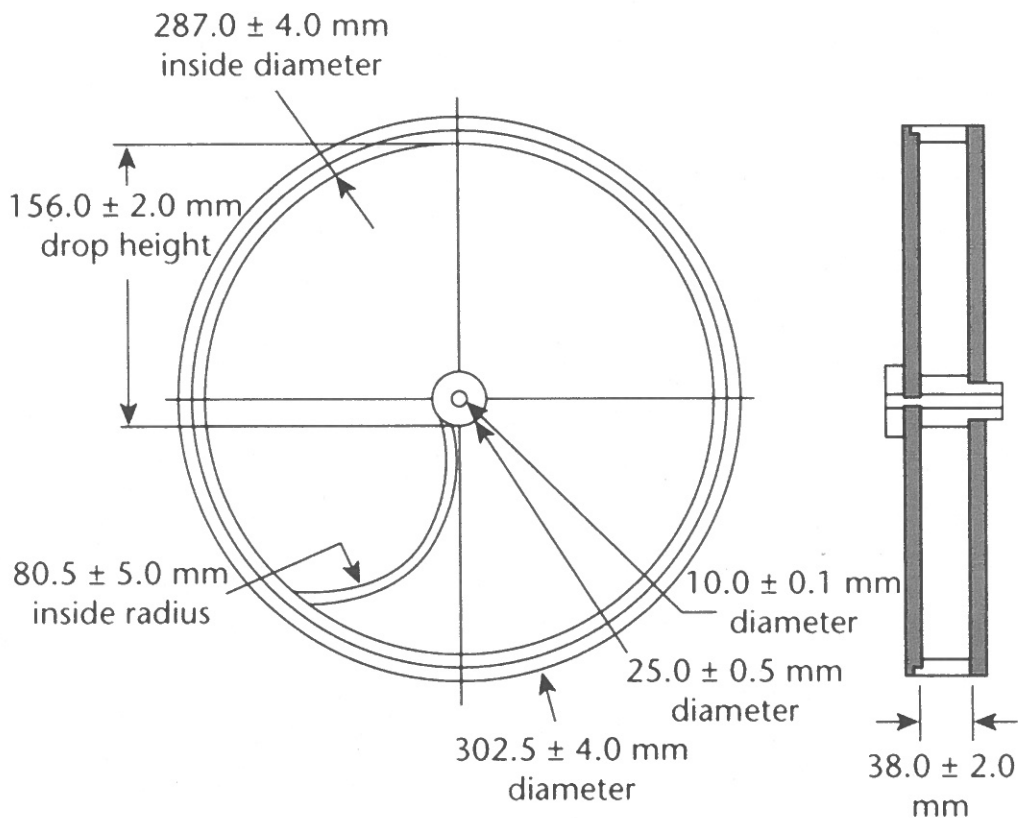

Tablet Friability Apparatus

20  
21  
22  
23  
24  
25

#### PROCEDURE

yg  
KJM  
DN

26 For tablets with a unit weight equal to or less than 650 mg, take a sample of whole  
27 tablets corresponding as near as possible to 6.5 g. For tablets with a unit weight of more  
28 than 650 mg, take a sample of 10 whole tablets. The tablets should be carefully dedusted  
29 prior to testing. Accurately weigh the tablet sample and place the tablets in the drum.  
30 Rotate the drum 100 times using a speed from 24 to 26 rpm and remove the tablets.  
31 Remove any loose dust from the tablets as before, and accurately weigh.

32 Generally, the test is run once. If obviously cracked, cleaved, or broken tablets are  
33 present in the tablet sample after tumbling, the sample fails the test. If the results are  
34 difficult to interpret or if the weight loss is greater than the target value, the test should be  
35 repeated twice and the mean of the three tests determined. A weight loss from a single test  
36 or the mean of three tests of not more than 1.0% is considered acceptable for most  
37 products. Typically, in case of effervescent and chewable tablets the friability specifications  
38 may be different. If tablet size or shape causes irregular tumbling, adjust the drum base so  
39 that the base forms an angle of about 10° with the horizontal and the tablets no longer bind  
40 together when lying next to each other, which prevents them from falling freely.

41 In the case of hygroscopic tablets, an appropriate humidity-controlled environment is  
42 required during testing. Drums, with dual scooping projections, or an apparatus with more  
43 than one drum designed to test multiple samples at the same time, are also permitted.

44  
45

yg  
jcm  
DN